

SPECIFICATIONS	
CONTACT CARRIER MATERIAL	NYLON OR TPU
MOLDED MATERIAL/COLOR	TPU/BLUE-GRAY
HOUSING MATERIAL/PLATING	BRASS/NICKEL
CONTACT MATERIAL/PLATING	BRASS/GOLD
RATED CURRENT [A]	4.0 A
RATED VOLTAGE [V]	250 V
CABLE JACKET/COLOR	TPE/BLACK
CONDUCTOR INSULATION MATERIAL	HDPE (DATA), PVC (POWER)
NUMBER OF CONDUCTORS [AWG]	2x18 AWG, 2x22 AWG, 22 AWG DRAIN
SHIELDING	FOIL (PAIRS), ALUM. FOIL & T-C BRAID (OVERALL)
TEMPERATURE RATING	-40°C to +80°C (-40°F to +176°F)
PROTECTION CLASS	MEETS IEC IP67
ACCOMODATES WALL THICKNESS	UP TO .118" (3.0mm)

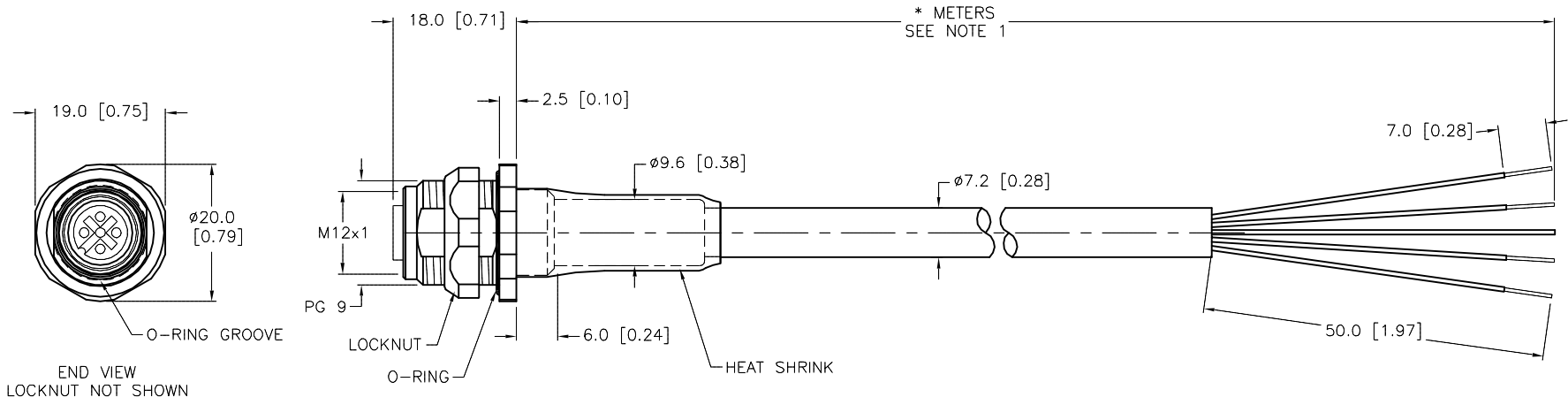

CABLE LENGTH	TOLERANCE*
ALL LENGTHS	+ 4% (OR 50mm) OF LENGTH - 0% (OR 0mm) OF LENGTH WHICHEVER IS GREATER
STRIP LENGTH	TOLERANCE*
0-7mm	±0.5mm
8-29mm	±1.0mm
30-49mm	±2.0mm
50-69mm	±3.0mm
70-100mm	±4.0mm
OVER 100mm	±5.0mm

* UNLESS OTHERWISE SPECIFIED

NOTES:
 1. "*" INDICATES CABLE LENGTH IN METERS. CONTACT TURCK TO ORDER SPECIFIC LENGTHS.

SOURCE DRAWING - FOR REFERENCE ONLY

RELATED DOCUMENTS 1. 2. 3. 4.	3RD ANGLE PROJECTION 	THIS DRAWING IS CONFIDENTIAL AND THE PROPERTY OF TURCK INC. USE OF THIS DOCUMENT WITHOUT WRITTEN PERMISSION IS PROHIBITED.		TURCK INC High Technology Sensors and Automation Controls 3000 CAMPUS DRIVE MINNEAPOLIS, MN 55441 1-800-544-7769 (763) 553-7300 (763) 553-0708 fax turck.com	
		DRFT RDS	DATE 05/28/13	DESCRIPTION FKSD 5736BK-*M	
MATERIAL	ALL DIMENSIONS DISPLAYED ON THIS DRAWING ARE FOR REFERENCE ONLY	APVD J.S.	SCALE 1=1.0	IDENTIFICATION NO.	
FINISH		UNIT OF MEASUREMENT MILLIMETER [INCH]		REV A	
CONTACT TURCK FOR MORE INFORMATION		DO NOT SCALE THIS DRAWING		FILE: 777031826	

A	DRAWING RELEASE	RDS	06/10/13	
REV	DESCRIPTION	BY	DATE	ECO NO.